



# Test Report

**Application No.** : HXT240311120080

**Applicant** : Shenzhenshi Hengjiayongsheng Kejiyouxiangongsi

**Equipment Under Test (EUT)**

**EUT Name** : Knee Pad

**Model No.** : EU-HUDIE-B-M

**Serial No.** : See page 2

**Trademark** : BOSONER

**Receipt Date** : 2024-03-04

**Test Date** : 2024-03-04 to 2024-03-15

**Issue Date** : 2024-03-18

**Standards** : EN 14404:2004+A1:2010

**Test result** : **PASS**

The testing has been performed on the submitted samples and found in compliance with the standard (EU)2016/425 requirements.

**Test/Witness Engineer**



**Approved & Authorized**

*Andy Zhang*



This test report is valid for above tested sample only and shall not be reproduced in part without written approval of the laboratory.



<b>EN 14404:2004+A1:2010</b> Personal protective equipment - Knee protectors for work in the kneeling position	
Testing laboratory-----:	Shenzhen HuaXu Testing Technology Co., Ltd.
Address-----:	106, building B12, Yintian Industrial Zone, Yantian community, Xixiang street, Bao'an District, Shenzhen
Applicant-----:	Shenzhenshi Hengjiayongsheng Kejiyouxiangongsi
Address-----:	GuangdongshengshenzhenshiLonggangqu Pinghujiedao HehuashequHuanandadaoyihao Huananguoji PigejijuYuanfuliaowuliuquerqi4B-063
Standard-----:	EN 14404:2004+A1:2010
Test result-----:	Compliance with the requirements.
Procedure deviation-----:	N.A.
Non-standard test method---	N.A.
Trademark-----:	BOSONER
Type of test object-----:	Knee Pad
Models/Type reference-----:	EU-HUDIE-B-M, EU-HUDIE-heihong-s, EU-HUDIE-fense-s, EU-HUDIE-heise-m, EU-HUDIE-heihong-m, EU-HUDIE-heise-s, EU-HUDIE-fense-m, EU-CCHD-Grün-M, EU-CCHD-Blauviolett-M, EU-CCHD-Rosa-S, EU-CCHD-Grün-S, EU-CCHD-Lila-M, EU-CCHD-Rosa-M, EU-CCHD-Schwarz-M, EU-CCHD-Lila-S, EU-CCHD-Blauviolett-S, EU-CCHD-Schwarz-S, EU-HUDIE-BL-S, EU-HUDIE-BBL-M, EU-HUDIE-BR-S, EU-HUDIE-BBL-S, EU-HUDIE-BL-M, EU-HUDIE-BR-M, EU-HUDIE-P-S, EU-HUDIE-PU-S, EU-HUDIE-B-S, EU-HUDIE-B-M, EU-HUDIE-P-M, EU-HUDIE-PU-M
Material-----:	POLYESTER
Factory-----:	Shenzhenshi Hengjiayongsheng Kejiyouxiangongsi
Address-----:	GuangdongshengshenzhenshiLonggangqu Pinghujiedao HehuashequHuanandadaoyihao Huananguoji PigejijuYuanfuliaowuliuquerqi4B-063



<b>Test item particulars:</b>	
Operating condition-----:	N.A.
Class of equipment -----:	N.A.
Protection against ingress of water-----:	N.A.
<b>Possible test case verdicts:</b>	
Test case does not apply to the object-----:	N
Test object does meet the requirement -----:	P
Test object does not meet the requirement-----:	F
<b>General product information:</b>	
Unless otherwise specified, test are carried out in a draught-proof room at (20 ± 5) °C.	
<b>General remarks:</b>	
1." (see remark #) " refers to a remark appended to the report.	
2. Throughout this report a point is used as the decimal separator.	
3. The test results presented in this report relate only to the object tested.	
4. All models are the same except model name and sharp.	
5. This report shall not be reproduced except in full without the written approval of the Shenzhen HuaXu.	
6. If client has any objection to the testing results, please advise us within 15 working days after publish, otherwise claims will not be accepted.	



---

---

## Artwork of Marking Label

**Knee Pad**

Model No: EU-HUDIE-B-M



Shenzhenshi Hengjiayongsheng Kejiyouxiangongsi

Guangdongshengshenzhenshi Longgangqu Pinghujiedao  
Hehuashequ Huanandadaoyihao Huananguoji  
Pigepiju Yuanfuliaowuliuquerqi4B-063

Made in China



EN 14404			
CL.	Requirement of the test	Result--Remark	Verdict
<b>3</b>	<b>Terms and definitions</b>		<b>P</b>
	For the purposes of this document, the following terms and definitions apply.		P
3.1	knee protectors devices used by people kneeling down to protect their knees		P
3.2	Type 1 knee protectors knee protectors that are independent of other clothing and fasten around the leg		P
3.3	Type 2 knee protectors foam plastic or other padding material in pockets on trouser legs, or permanently attached to trousers	The position of Type 2 knee protectors on trousers may be fixed or adjustable.	P
3.4	Type 3 knee protectors devices not attached to the body, but put into place as the user moves around. These may be for each knee or both knees together		P
3.5	Type 4 knee protectors knee protectors for one or both knees, which are parts of devices with additional functions such as a frame to aid standing up, or a kneeling seat. The knee protectors may be worn on the body or be independent		P
3.6	fastening part of a knee protector, which keeps it in the right position		P
3.7	zone of protection area of protective equipment that is intended to provide protection, and is subject to specific testing		P
3.8	centre of the back of the knee junction of the skin of the thigh and the shin when the knee is flexed to an angle of 90° at the centre of the popliteal fossa		P
<b>4</b>	<b>Performance levels</b>		<b>P</b>
	Two performance levels are defined by performance requirements in laboratory tests given in Clauses 5 and 6. – level 1 knee protectors are expected to be suitable for use on flat floor surfaces where objects more than 1 cm high are not a common hazard – level 2 knee protectors are expected to be suitable for use in severe conditions such as when kneeling on broken rocks in mining and quarry work	Performance levels are defined by the severity of the test conditions.	P
<b>4</b>	<b>Performance levels</b>		<b>P</b>



EN 14404			
CL.	Requirement of the test	Result--Remark	Verdict
	<p>Two performance levels are defined by performance requirements in laboratory tests given in Clauses 5 and 6.</p> <ul style="list-style-type: none"> <li>– level 1 knee protectors are expected to be suitable for use on flat floor surfaces where objects more than 1 cm high are not a common hazard</li> <li>– level 2 knee protectors are expected to be suitable for use in severe conditions such as when kneeling on broken rocks in mining and quarry work</li> </ul>	Performance levels are defined by the severity of the test conditions.	P
<b>5</b>	<b>Requirements</b>		<b>P</b>
5.1	<p>General requirements</p> <p>Knee protectors shall meet a general requirement that they are safe to use and fit for their purpose. They shall be designed and manufactured to provide protection when used according to the manufacturer's instructions, without endangering the user. Knee protectors shall meet the innocuousness requirements of EN 340. There shall not be hard or sharp edges, seams, buckles or other items on the inner surfaces of the products that could harm the user during normal use. Examination shall be made according to 6.4.</p> <p>Construction materials and incorporated substances shall not harm those coming into contact with them. The manufacturer shall list in the information supplied with the product, the substances used in the main components of the product, and shall label any product containing substances or preparations generally known to be hazardous, as defined in EN 340.</p>		P
5.2	Requirements for knee protectors		P
5.2.1	<p>Summary of specific requirements</p> <p>Table 1 summarizes the specific requirements for the different Types of knee protectors.</p>		P
5.2.2	<p>Type 4 – Knee protectors</p> <p>Type 4 knee protectors shall meet the requirements for Type 1 or Type 3 knee protectors depending on whether they are worn on the body or are independent, as applicable.</p>		P
5.2.3	<p>Size</p> <p>All knee protectors shall be marked with their size based on the waist girth of the users they are intended to fit. The sizing shall be explained in the information supplied by the manufacturers.</p>		P



EN 14404			
CL.	Requirement of the test	Result--Remark	Verdict
5.2.4	<p>Dimensions</p> <p>The zones of protection shall have dimensions as specified in Table 2. The values of the dimensions shall be calculated from the waist girth of largest size of the user the protector is designed to fit, or in the case of "one size fits all" products a waist girth of 120 cm. The shapes of the zones of protection are shown in Figure 1.</p> <p>When measured according to 6.4 on the inside of the knee protector the material providing protection shall be larger than the minimum zone of protection calculated from Table 2.</p>		P
5.2.5	<p>Penetration resistance</p> <p>Knee protectors conforming to performance level 1 shall resist complete penetration at a force of at least <math>(100 \pm 5)</math> N, and knee protectors conforming to performance level 2 shall resist complete penetration at a force of at least <math>(250 \pm 10)</math> N, when tested in accordance with 6.5. The internal face of the knee protectors shall not deflect by more than 5 mm.</p>		P
5.2.6	<p>Force distribution</p> <p>When tested according to 6.6 the mean force recorded by each transducer shall be less than 30 N in the tests on the flat anvil.</p>		P
5.2.7	<p>Peak transmitted force</p> <p>When tested in accordance with 6.7 the peak transmitted forces in test impacts shall not exceed the values in Table 3 in impacts at the energies given in Table 3</p>		P
5.2.8	<p>Restraint</p>		P
5.2.8.1	<p>General</p> <p>Type 1 and Type 2 knee protectors that are worn on the body shall be provided with a restraint system that ensures that they are correctly placed for working in the kneeling position. This restraint may be achieved using integral straps with buckles, touch and close fasteners, separate "harness" or other items of protective equipment or clothing. The manufacturer shall give details of how adequate restraint of the knee protectors may be achieved in the Information supplied by the manufacturer.</p>		P



EN 14404			
CL.	Requirement of the test	Result--Remark	Verdict
5.2.8.2	<p>Type 1 Knee protectors Knee protectors that fasten around the leg shall be provided with straps at least 40 mm wide. Straps shall be continuously adjustable. No part of a strap shall pass within 10 mm of the centre of the back of the knee when the protector is on a leg and the knee is bent. Assessment shall be made according to 6.4.</p> <p>The restraint system for the knee protectors shall be assessed as described in 6.8.1. The knee protector shall not be displaced by more than 5 cm, when the test force is applied and shall return to within 2 cm of its initial position when the force is removed. The force to be resisted shall be <math>(10 \pm 1)</math> N.</p> <p>If knee protectors are restrained by a system that does not use straps the manufacturer shall demonstrate that venous drainage is unlikely to be impaired. (See informative Annex A)</p>		P
5.2.8.3	<p>Type 2 Knee protectors Knee protectors in trousers shall be held in closed pockets or attached to the trousers in another way. If not in pockets they shall not be removable by a force of <math>(100 \pm 5)</math> N as described in 6.8.2</p>		P
5.3	<p>Optional requirements – water resistance When tested according to 6.9 the inside surface of the knee protectors and the filter paper shall remain dry</p>		P
5.4	<p>Ergonomic requirements</p>		P
5.4.1	<p>Restraint and comfort during use Knee protectors shall be found acceptable in wearer trials conducted according with 6.10.1 to 6.10.4</p>		P
5.4.2	<p>Compliance of straps The restraint system for Type 1 knee protectors shall be elastic. When retained by straps the force required to stretch any strap according to 6.11 by 4 cm shall be less than <math>(10 \pm 1)</math> N.</p>		P
<b>6</b>	<b>Test methods</b>		<b>P</b>



EN 14404			
CL.	Requirement of the test	Result--Remark	Verdict
6.1	<p>General</p> <p>Measuring instruments unless otherwise specified shall be accurate to <math>\pm 2\%</math> of the pass/fail level of the characteristic being measured.</p> <p>For each of the required sequences of measurements performed in accordance with this standard a corresponding estimate of the uncertainty of the final result shall be determined. This uncertainty (<math>U_m</math>) shall be given in the test report in the form <math>U_m = \pm X</math>. It shall be used in determining whether a "Pass" performance has been achieved. If the final result minus <math>U_m</math> is below the pass level when the requirement that a certain value shall be exceeded, the sample shall be deemed to have failed.</p>		P
6.2	<p>Products for testing</p> <p>At least eight pairs of knee protectors shall be supplied for testing. At least one pair shall be supplied of each size that is placed on the market. They shall be complete and ready to use. Knee protectors shall be supplied complete with the labels and information supplied by the manufacturer. Knee protectors for fitting into trousers shall be supplied with appropriate trousers. They shall be tested in the pockets from these trousers. For protectors fitted to trousers supplied in more than five sizes, five representative sizes of trousers only need to be supplied.</p>		P
6.3	<p>Conditioning</p>		P
6.3.1	<p>Before all test procedures</p> <p>Unused knee protectors (and trousers) shall be conditioned for at least 24 h at a temperature of <math>(20 \pm 2)^\circ\text{C}</math> and a relative humidity of <math>(65 \pm 5)\%</math> prior to testing. Tests shall to be made in this atmosphere or within 10 min from removing the test specimen from there.</p>		P
6.3.2	<p>Before peak transmitted force measurement</p> <p>Each impact test site marked according to 6.4 and 6.7.2 shall be impacted four times at 5 J prior to impacting at 5 J and the recording of the peak transmitted force. All impacts on a test site shall be completed within 5 min.</p>		P



EN 14404			
CL.	Requirement of the test	Result--Remark	Verdict
6.4	<p>Examination</p> <p>Knee protectors shall be examined visually and by hand to locate any hard or sharp edges, seams, buckles, or other items that might injure the user or others during normal use. Documents supplied by the manufacturer shall be examined to determine whether the claim that the materials are suitable for use in protective clothing and equipment is justified. Testing to ensure that the requirement is met shall be carried out if the documents examined are not adequate. The information supplied by the manufacturer (Clause 8) shall be examined for a list of substances used in the main components of the products. The results of the examination shall be recorded in the test report.</p> <p>The dimensions of the product, restraint systems and adjustments, shall be measured with appropriate tape measures or other devices accurate to within 1 % of the dimension being measured. The results shall be compared with the calculated values for the dimensions determined from the requirements in 5.2.4, for the largest intended user indicated in the information supplied by the manufacturer. The size marked on the product and details in the Information supplied by the manufacturer (see Clause 8) shall be examined to determine whether the product corresponds to the marking and to the information given. The results of the examination shall be recorded in the test report.</p> <p>The knee protectors shall be marked on their outer surfaces with the minimum required dimensions of the zones of protection for their sizes based on the size of the largest intended user. All sizes shall be examined to determine whether their construction appears to provide similar protection throughout the required zone of protection. At least one knee protector shall be taken apart to verify its construction. Any areas with apparently reduced protection shall be marked for subsequent mechanical testing.</p> <p>Type 1 knee protectors shall be put on by appropriately sized subjects and the positions of the straps shall be examined. It shall be verified that no edge of a strap is closer than 10 mm to the centre of the back of the knee, when the knee is bent after five complete flexing and extending movements.</p>		P



EN 14404			
CL.	Requirement of the test	Result--Remark	Verdict
6.5	<p>Penetration resistance</p> <p>Penetration resistance shall be measured according to EN 863 at velocity of <math>(100 \pm 10)</math> mm/min. Five tests shall be made distributed throughout the zone of protection of the knee protector, including potentially weak points. The test spike shall be applied to the outer face of the knee protector. The maximum deflection of the inner face of the knee protector shall be measured by a method having a resolution of <math>&lt; 0,5</math> mm.</p>		P
6.6	Force distribution		P
6.6.1	<p>Apparatus</p> <p>A test knee shall be used. It shall be made out of hard plastics, wood or metal. The BIA test knee "Kandy" is suitable. It is illustrated in Figures 2 and 3. The test knee shall be equipped with three force transducers placed as shown in Figures 2 and 3. The surface of the transducers shall be shaped to match the surface of the "Kandy" knee at the points where they are inserted. The surfaces shall follow the profile of the original "Kandy" knee with a tolerance of <math>\pm 0,5</math> mm. The transducers shall have the dimensions shown in Figure 4. The force transducers shall be connected to a recording system. The overall accuracy of the system shall be <math>\pm 1</math> N.</p> <p>The test knee shall be attached to the cross head of a compression tester. The test knee shall be orientated in the apparatus so that the inclined plane (4) contacting the centre line of the knee at two points (6 and 7) a distance <math>l</math> (<math>170 \pm 30</math>) mm apart is at an angle <math>\alpha</math> (<math>5 \pm 0,5</math>)° to the horizontal plane. A flat horizontal anvil shall be provided to support knee protectors during testing</p>		P
6.6.2	<p>Procedure</p> <p>The protector to be tested shall be placed so that the test knee will press into it at a position similar to where a user's knee would be. Type 1 and type 2 protectors shall be attached with straps or adhesive tape.</p> <p>The test knee shall be advanced at <math>(50 \pm 5)</math> mm/min till a total force of <math>(750 \pm 10)</math> N has been reached. This force shall be maintained for <math>(20 \pm 2)</math> s. The force at each of the transducers in the knee shall be measured and the value <math>(15 \pm 1)</math> s after the compression force of 750 N is reached, shall be recorded. Three knee protectors shall be tested. The mean values of the results from each transducer shall be calculated.</p>		P
6.7	Impact testing		P



EN 14404			
CL.	Requirement of the test	Result--Remark	Verdict
6.7.1	<p>Apparatus</p> <p>Knee protectors shall be impact-tested with a falling mass in a vertical guidance system that allows the terminal velocity of the falling mass to be measured and to be within <math>\pm 2\%</math> of the required velocity. The total mass shall be <math>(2\,500 \pm 100)</math> g including a flat faced steel striker <math>(80 \pm 1)</math> mm in diameter.</p> <p>The drop heights of the mass above the top surface of the knee protector shall be adjusted so that the impact velocities provide impact energies as specified in Table 3, with an accuracy of <math>\pm 5\%</math>.</p> <p>The anvil as shown in Figure 4 shall consist of a vertical steel cylinder <math>(100 \pm 2)</math> mm in diameter mounted directly onto a load cell or force transducer, such as a piezo-electric load cell. The anvil shall have a hemispherical <math>(50 \pm 1)</math> mm radius upper end. The anvil shall have a height of at least <math>(220 \pm 20)</math> mm. The anvil shall be made of steel and the mass above the load cell shall be <math>(10 \pm 1,5)</math> kg. The anvil and load cell shall be bolted or clamped to a concrete or similar massive base of at least 1 000 kg</p> <p>The frequency response of the load transducer shall be at least 10 kHz. The recording system shall show a continuous force with time, or shall have a peak force detection capability. Sampling systems shall have a minimum rate of 10kHz. The complete system shall be able to measure forces up to 10 kN with an accuracy of <math>\pm 0,05</math> kN between 1 kN and 10 kN.</p> <p>Elastic straps exerting a force of <math>(25 \pm 5)</math> N shall be provided to hold the test specimens in contact with the anvil.</p>		P



EN 14404			
CL.	Requirement of the test	Result--Remark	Verdict
6.7.2	<p>Procedure</p> <p>Test specimens shall be prepared from knee protectors that have had the minimum dimensions of the zones of protection marked on their outer surface. If necessary the protectors shall be cut up and straps removed so that the protector can be placed with its inner surface in contact with the anvil. The elastic straps shall be used to hold it in place. If the product loses its integrity on being cut up, the cut edges shall be bound with adhesive tape to retain the normal relationship between the components of the product.</p> <p>If the construction of the knee protector is similar throughout the zone of protection, five impact test sites shall be marked on the protector. The centres of impacts shall be not less than 60 mm apart, nor less than 30 mm from the edge of the zone of protection marked on the test specimen. If areas with different constructions, or areas possibly providing reduced protection were noted in the examination according to 6.4, two additional impact sites shall be marked on each type of these areas. Each marked impact site shall be tested in the same way. The protector shall be placed on the anvil and struck by the impactor with the energy given in Table 3, on the centre of the impact site. The protector shall be re-positioned and struck a further three times on the site. A final impact on the site is the test impact and the transmitted force from this shall be recorded. All the four pre-conditioning impacts and the test impact shall be completed within 5 min.</p> <p>The sequence of pre-conditioning and test impacts shall strike the same part of the protector. An accuracy of <math>\pm 1</math> mm should be attained. It is recommended that the impact test site is marked by a line drawn around it with an 80 mm diameter template. The impactor lowered onto the protector can then be used in positioning the protector each time to the same position prior to raising the impactor to the appropriate drop height. Protectors in fabric pockets shall be fixed to the fabric, or the pocket shall be reduced in size to firmly restrain the protector within it. Staples, stitches or another suitable system may be used. The aim is to ensure that the same part of the protector lies under the impact site marked on the fabric throughout the pre-conditioning and test impacts.</p> <p>The mean value of all the results from all the test impacts and the values of the individual test impacts shall be given in the test report</p>		P
6.8	Restraint testing		P



EN 14404			
CL.	Requirement of the test	Result--Remark	Verdict
6.8.1	<p>Type 1 – Knee protectors</p> <p>The knee protector shall be attached to a dummy or to a model body part, or shall be put on by a subject. The dummy or subject shall have dimensions within those specified by the manufacturer for users of the knee protector. The knee protector shall be restrained, and adjusted according to the Information supplied by the manufacturer.</p> <p>A spring balance, force gauge, or other suitable device shall be attached to the lower edge of the knee protector and the test force applied in a direction down the leg parallel to the long axis of the shin bone.</p> <p>The force of <math>(10 \pm 1)</math> N shall be maintained for at least 30 s and then released. The movements of the knee protector when the force is applied, and when it is removed, shall normally be measured to an accuracy of 5 % of the maximum permitted displacements. If the movement is less than 75 %, or greater than 150 % of the permitted maximum movement, this fact may be recorded instead of a precise measurement. Between measurements, the position of the knee protector and the adjustment of the restraint system shall be corrected. The test shall be carried out three times. The procedure shall be repeated pulling the knee protector up the leg.</p>		P
6.8.2	<p>Type 2 – Knee protectors</p> <p>Knee protectors attached to trousers, but not in closed pockets shall be tested by attaching a clamp in turn to each corner and pulling the knee protector directly away from the leg (normal to the long axis of the leg) with a force of <math>(100 \pm 5)</math> N. The force shall be maintained for 10 s. Any detachment of the knee protector shall be recorded.</p>		P
6.9	Water resistance of knee protectors		P



EN 14404			
CL.	Requirement of the test	Result--Remark	Verdict
6.9.1	<p>Type 1 – Knee protectors            A piece of filter paper (<math>0,175 \pm 0,025</math>) mm thick shall be cut to fit inside the knee protector in contact with the inner face of the knee protector. The knee protector shall be attached to the test knee specified in 6.6.1 in the compression tester.            A container for water shall be provided with a surface area of (<math>2\ 500 \pm 500</math>) cm<sup>2</sup>. The container shall be filled to a depth of (<math>5 \pm 1</math>) mm with tap water. The knee protector on the test knee shall be advanced into the water at (<math>50 \pm 5</math>) mm/min until a force of (<math>750 \pm 10</math>) N has been reached. This force shall be maintained for (<math>30 \pm 3</math>) s. The knee protector shall be unloaded and the procedure repeated a total of 50 times. Each cycle duration shall be (<math>2 \pm 0,5</math>) min.            After the 50 cycles the filter paper and inside of the knee protector shall be examined for wetting.</p>		P
6.9.2	<p>Type 3 – Knee protectors            The test shall be conducted with the protector placed in the water container.</p>		P
6.9.3	<p>Type 4 – Knee protectors            The test shall be conducted by an appropriate modification of the above procedures.</p>		P
6.10	Ergonomic testing - Wearer trials		P
6.10.1	<p>Type 1 – Knee protectors            Five subjects of different body dimensions within the size range of users the knee protectors are intended to fit shall be available.            A subject who is medically fit and with no knee injuries and of an appropriate size shall put on a pair of knee protectors. The subject shall adjust the straps or other fixings according to the manufacturer's instructions. The subject shall walk around for (<math>15 \pm 1</math>) min and during this time kneel down and stand up ten times. The subject shall also shuffle forwards for (<math>10 \pm 1</math>) m on their knees on a smooth concrete surface at about the tenth minute during the test. The subject shall not adjust or re-position the knee protectors during the test and on one occasion shall remain kneeling for (<math>5 \pm 0,5</math>) min.            Two further subjects shall repeat the test.            The knee protectors are acceptable if two subjects report positively on positioning and comfort. If all three subjects report negatively the knee protectors have failed the test. If two subjects report negatively, two further subjects shall carry out the test. If both of these report positively the knee protectors are acceptable, otherwise they fail this test.</p>		P



EN 14404			
CL.	Requirement of the test	Result--Remark	Verdict
6.10.2	<p>Type 2 – Knee protectors</p> <p>The test procedure for Type 1 knee protectors shall be followed for Type 2 knee protectors. The subjects shall wear trousers that fit them correctly, and are designed to accept the knee protectors to be tested. The subjects shall report particularly on whether the knee protectors are correctly positioned between their knees and the ground when they kneel down.</p>		P
6.10.3	<p>Type 3 – Knee protectors</p> <p>The test procedure for Type 1 knee protectors shall be followed for Type 3 knee protectors except that shuffling forward shall not be attempted. The subject shall carry the protector between kneeling down actions. The subject shall report on the ease with which he/she can correctly position their knees in the protector and the comfort of their knees, shins and thighs while kneeling.</p>		P
6.10.4	<p>Type 4 – Knee protectors</p> <p>Type 4 knee protectors shall be assessed by a procedure derived from those above that is appropriate for the design of the incorporated knee protectors.</p>		P
6.11	<p>Compliance of straps</p> <p>Straps restraining Type 1 and Type 4 knee protectors shall be tested with the apparatus shown in Figure 5. The knee protector shall be placed on a solid base. A solid cylinder of wood metal or plastic at least 200 mm long with a diameter of <math>(110 \pm 5)</math> mm and a mass of <math>(7 \pm 2)</math> kg shall be placed in the knee protector with a light hollow metal or plastic half cylinder placed above it. This half cylinder shall have a polished surface on which fabric straps should slide freely. The restraining straps of the knee protector shall be done up around the cylinder and the half cylinder according to the manufacturer's instructions. The straps shall be adjusted so that they are not loose. A force equal to the mass of the half cylinder plus <math>(10 \pm 1)</math> N per strap shall be applied to lift the half cylinder vertically upwards and to stretch the restraining strap or straps. The distance the half cylinder moves shall be measured. It shall be verified that this movement stretches each of the restraining straps by at least 40 mm. (If the half cylinder moves 20 mm the strap has normally stretched 40 mm).</p>		P



EN 14404			
CL.	Requirement of the test	Result--Remark	Verdict
<b>7</b>	<b>Marking</b>		<b>P</b>
	<p>Knee protectors shall be permanently and conspicuously marked with at least the following in the official language(s) of the state or region in which they are placed on the market:</p> <p>a) For Type 2 knee protectors sewn into pockets on trousers the marking shall be repeated on the trousers.</p> <p>b) The name or trademark of the manufacturer or his authorised representative in the European Union or country where the product is placed on the market.</p> <p>c) Designation of the product type, including the Type designation according to this Standard, commercial name or code that uniquely identifies the item.</p> <p>d) The size designation of the item.</p> <p>e) The reference number of this document and the level of performance of the item. f) A mark designating the inner (or outer) surface of Type 2 knee protectors.</p> <p>g) If relevant, the side of the body on which the protector should be worn</p> <p>h) An instruction to see the Information supplied by the manufacturer (see Clause 8) provided with the product.</p> <p>The following information should be given on the product whenever practical:</p> <p>i) The type of use for which the protectors are intended. Any type of use for which the protectors are specifically not intended.</p> <p>j) The hazards specific to kneeling work against which protection is not given. (This information should be emphasised by the use of bold type).</p> <p>k) Textile and material types in the protector.</p> <p>l) International care label symbols according to EN 23758 if appropriate. (Negative labels are important.)</p>		<b>P</b>
<b>8</b>	<b>Information to be supplied by the manufacturer</b>		<b>P</b>



EN 14404			
CL.	Requirement of the test	Result--Remark	Verdict
	<p>Knee protectors shall be supplied with information and instructions for fitting and use that will promote their safe and effective use. The information shall be precise and comprehensible and in the official language(s) of the state or region in which they are placed on the market. The information shall contain at least the following:</p> <ul style="list-style-type: none"><li>a) all the information required in 7 a) to l);</li><li>b) the full address of the manufacturer or importer;</li><li>c) name and full address and identification number of the Notified Body involved in type approval and/or quality control;</li><li>d) reference number of this document and any others applicable with the year(s) of publication;</li><li>e) how to select protectors of the correct level of performance. An explanation of the levels of performance of protectors available under this standard;</li><li>f) a statement as to whether the protector is water resistant;</li><li>g) information concerning additional protection provided by the knee protector because it complies with additional standards relating for example to fire resistance or chemical resistance;</li><li>h) details of the sizes of protector available and the body dimensions to which they relate;</li><li>i) how to choose the correct size of protector and check its fit</li><li>j) an explanation of the mark designating the inner (or outer) surface of Type 2 knee protectors;</li><li>k) how to adjust the protectors. With if appropriate illustrations of where any the straps should be positioned;</li><li>l) for Type 2 knee protectors, the designation of suitable trousers for use with the knee protector;</li><li>m) instructions about wearing other PPE to obtain the protection desired;</li><li>n) a warning about any changes in environmental conditions, such as temperature, that would significantly reduce the performance of the protector;</li><li>o) a warning that no protector can offer full protection against injuries, and details of the problems that may occur;</li><li>p) a warning about any contamination, alteration to the protector, or misuse that would dangerously reduce the performance of the protector;</li><li>q) a list of the substances used in the main components of the product;</li><li>r) detailed instructions for caring for and cleaning the protector;</li><li>s) instructions concerning inspection and repair of the protector, and how to decide that it should be thrown away because it may no longer provide adequate protection.</li></ul>		P



---

---

## **Annex A (informative)**

### **Information on the problems of using knee protectors for work in the kneeling position**

#### A.1 General

The kneeling position is not natural for humans, and the anatomy of the knee is not appropriate for the long term loads imposed during kneeling. However the kneeling position can be very convenient for some tasks. During them discomfort and injury may occur, hence workers wish to wear knee protectors which are soft on the inside.

Knee protection provided by something soft to kneel on does not prevent all the problems of pressure and discomfort, and long term skin changes may occur. Adoption of a kneeling position can also always be expected to compromise venous drainage from the lower leg. Inactivity of the calf muscles limits the pressure driving venous blood up the leg and the bent knee inevitably results in compression of popliteal veins and an increase in resistance to blood flow through them. Sitting without movement with the knee bent as in an aircraft is equally well known to lead to circulatory problems such as ankle oedema and deep vein thrombosis even without pressure on the knee. If the knee protection is provided by protectors held onto the legs with straps the problems are worse as these contribute to the pressure restricting venous drainage.

#### A.2 Advice to users

The following advice can be given to users of knee protectors:

- a) ensure your knee protectors conform to this document and are in good condition;
- b) consider whether knee protectors not strapped onto your legs could be used, as they are preferable;
- c) do not over tighten the straps if you need to use them. Wear any straps as loose as is practical to stop your knee protectors sliding off;
- d) ensure the straps are not constricting when you kneel down;
- e) kneel upright, do not sit on your heels;
- f) move around, do not stay still;
- g) do not kneel for longer than an hour with any protectors without getting up and walking around;
- h) walk around without knee protectors strapped to your legs for at least 10 min after kneeling for one hour;
- i) seek medical advice if your knees or calves swell during kneeling work.

## Annex ZA (informative)

### Relationship between this European Standard and the Essential Requirements of EU Directive 89/686/EEC

This European Standard has been prepared under a mandate given to CEN by the European Commission and the European Free Trade Association to provide a means of conforming to Essential Requirements of the New Approach Directive 89/686/EEC.

Once this standard is cited in the Official Journal of the European Communities under that Directive and has been implemented as a national standard in at least one Member State, compliance with the clauses of this standard given in Table ZA confers, within the limits of the scope of this standard, a presumption of conformity with the corresponding Essential Requirements of that Directive and associated EFTA regulations.

Table ZA — Correspondence between this European Standard and Directive 89/686/EEC

Clause(s)/sub-clause(s) of this EN	Essential Requirements (ERs) of Directive 89/686/EEC, Annex II
Introduction	1 All risks encountered
4	1.1.2.1 Highest level of protection possible
4	1.1.2.2 Classes of protection appropriate to different levels of risk
5.1	1.2 Innocuousness of PPE
5.1	1.2.1 Absence of risk of other inherent nuisance factors
5.1	1.2.1.1 Suitable constituent materials
5.1	1.1 Design Principles
5.1	1.1.1 Ergonomics
5.1	1.2.1.2 Satisfactory surface condition of all parts of PPE in contact with user
5.2	1.1 Design Principles
5.2.3, 5.2.4	1.3.1 Adaptation of PPE to user morphology
5.2.5	3.3 Protection against physical injury (abrasion, perforation, cuts, bites)
5.2.6, 5.2.7	3.2 Protection against (static) compression of body
5.2.7	2.4 PPE subject to ageing
5.3	1.1 Design Principles
5.3	3.10.2 Protection against cutaneous and ocular contact
5.4	1.1.1 Ergonomics
5.4	1.2.1.2 Satisfactory surface condition of all parts of PPE in contact with user
5.4	1.3.1 Adaptation of PPE to user morphology
5.4	1.2.1.3 Maximum permissible user impediment
5.4	1.3 Comfort and efficiency
8	1.4 Information supplied by the manufacturer

WARNING — Other requirements and other EU Directives may be applicable to the product(s) falling within the scope of this standard.



Table 1 — Summary of specific requirements for Types of knee protector and the tests applicable

Requirement		Type of protector to which the requirement applies	Clauses describing the tests applicable
Clause No.	Subject		
5.1	Innocuousness	All Types	EN 340 and 6.3.1 + 6.4
5.2.2	Type 4 protectors to meet requirements for Type 1 or Type 3 protectors as applicable	Type 4	6.3.1 + 6.4
5.2.3	Size designation and marking	All Types	6.3.1 + 6.4
5.2.4	Dimensions	All Types	6.3.1 + 6.5 (EN863:1995)
5.2.5	Penetration resistance (Performance levels 1 and 2)	All Types	6.3.2 + 6.3.1 + 6.6
5.2.6	Force distribution (Performance levels 1 and 2)	All Types	6.3.2 + 6.3.1 + 6.7
5.2.7	Peak transmitted force in impact (Performance levels 1 and 2)	All Types	6.4 + 8
5.2.8.1	General requirements for restraint	Type 1, Type 2 and Type 4 a	6.3.1 + 6.8.1
5.2.8.2	Restraint by straps or equivalent system	Type 1. Type 4	6.3.1 + 6.8.2
5.2.8.3	Restraint in pockets or by attachment to trousers	Type 2	6.3.1 + 6.9 Type 1, 6.9.1 Type 3, 6.9.2 Type 4, 6.9.3
5.3	Optional requirement for water resistance	Any type for which the claim is made. (Type 2 water resistance will depend on the properties of the trousers)	6.3.1 + Type 1, 6.10.1 Type 2, 6.10.2 Type 3, 6.10.3 Type 4, 6.10.4
5.4 5.4.1	Ergonomics Restraint and comfort during use	All Types All Types	
5.4.2	Compliance of straps	Type 1 and Type 4 a	6.3.1 + 6.10.5
7	Marking	All Types	Comparison with 7
8	Information for users	All Types	Comparison with 8

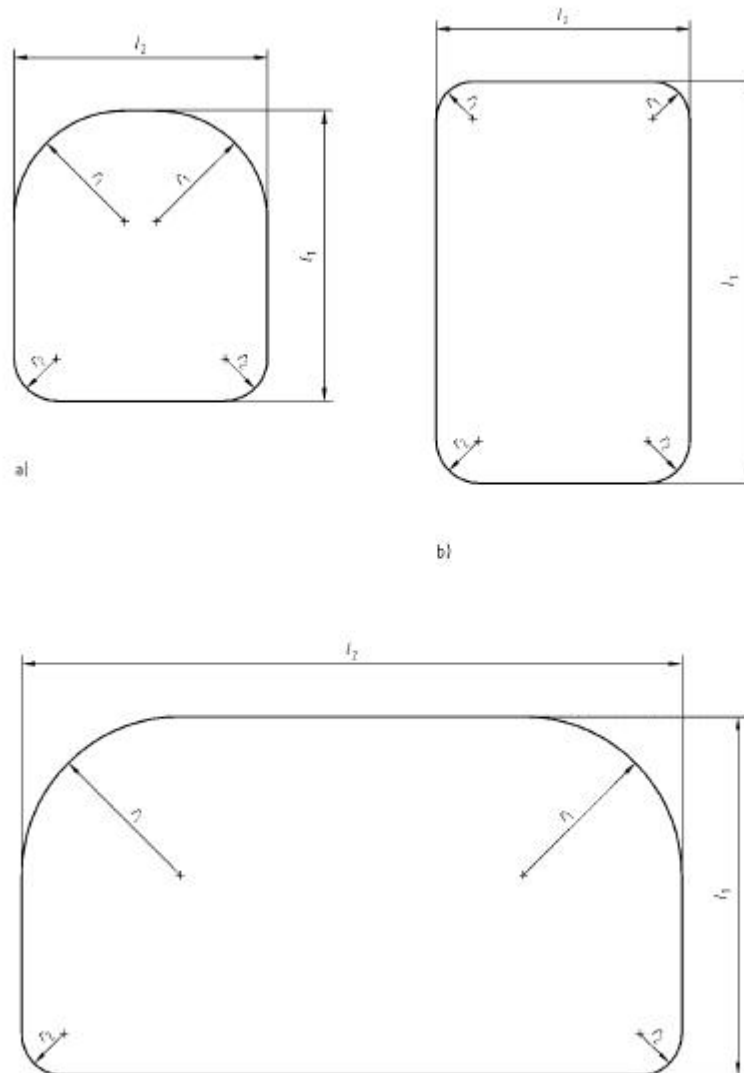

Table 2 — Dimensions of the zones of protection of knee protectors

Knee protector type	Minimum values for height and width of zones of protection of knee protectors expressed as a percentage of the waist girth of the largest intended user		Maximum values for the radius of curvature of corners of zones of protection, in mm	
	Height $l_1$	Width $l_2$	Proximal $r_1$	Distal $r_2$
Type 1	18	12	70	25
Type 2 - not adjustable, or loose in a pocket	24	12	25	25
- adjustable in a vertical direction by at least 4% of the waist girth of the largest intended user and capable of being fixed in position	20	12		
Type 3	24	40	100	25

Table 3 — Impact performance requirements

Impact energy J	Mean of all peak transmitted force measurements kN	Highest value of a single peak transmitted force kN
5	3	4



**Key**

$l_1$  Height of the zone of protection

$l_2$  Width of the zone of protection

$r_1$  Radius of curvature of a proximal (upper) corner of a knee protector

$r_2$  Radius of curvature of a distal (lower) corner of a knee protector

a) Type 1 knee protector

b) Type 2 knee protector

c) Type 3 knee protector

**Figure 1 — Shapes of the zones of protection of knee protectors**

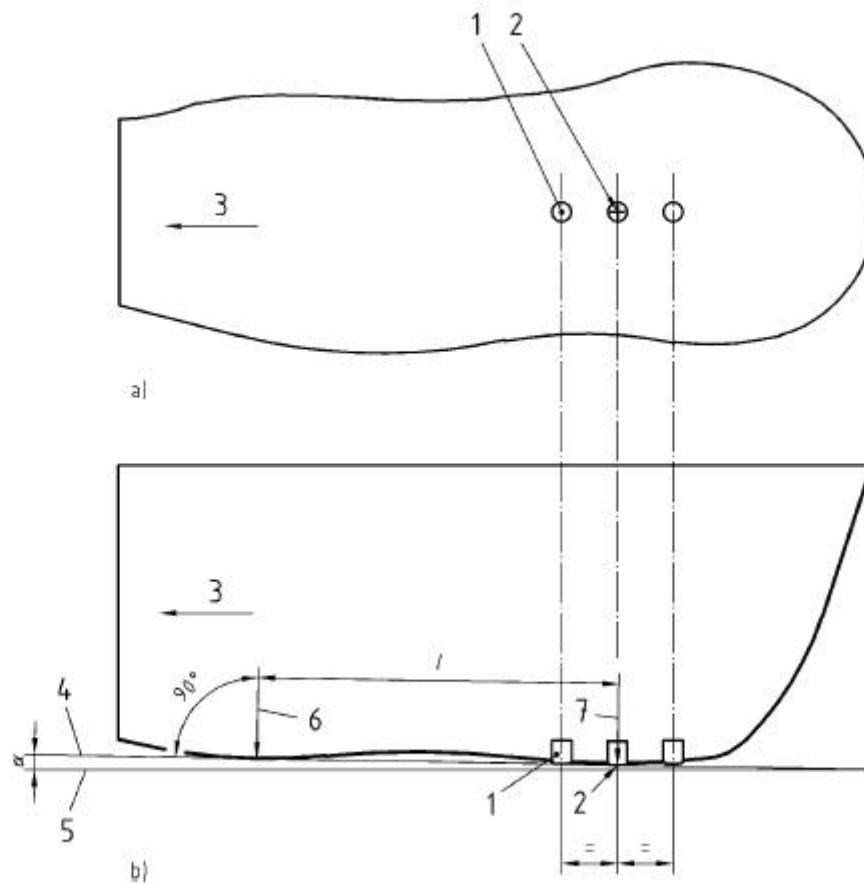

- a) Schematic side view of the test knee (medial view of the left knee and upper shin)  
 b) Bottom view of the test knee (anterior view of the left knee and upper shin)

#### Key

- 1) A force transducer
- 2) The centre of the face of the middle force transducer. This is the lowest point of the test knee.
- 3) The direction down the shin towards the ankle
- 4) The inclined plane contacting the middle force transducer and the surface of the shin region of the knee at point 6.
- 5) The horizontal plane
- 6 and 7) Contact points of the inclined plane
- l* Distance between 6 and 7 ( $170 \pm 30$ ) mm
- a* Angle between the inclined plane and the horizontal plane ( $5 \pm 0,5$ )°

Figure 2 — Shape of the test knee “Kandy” with the positions of the force transducers shown

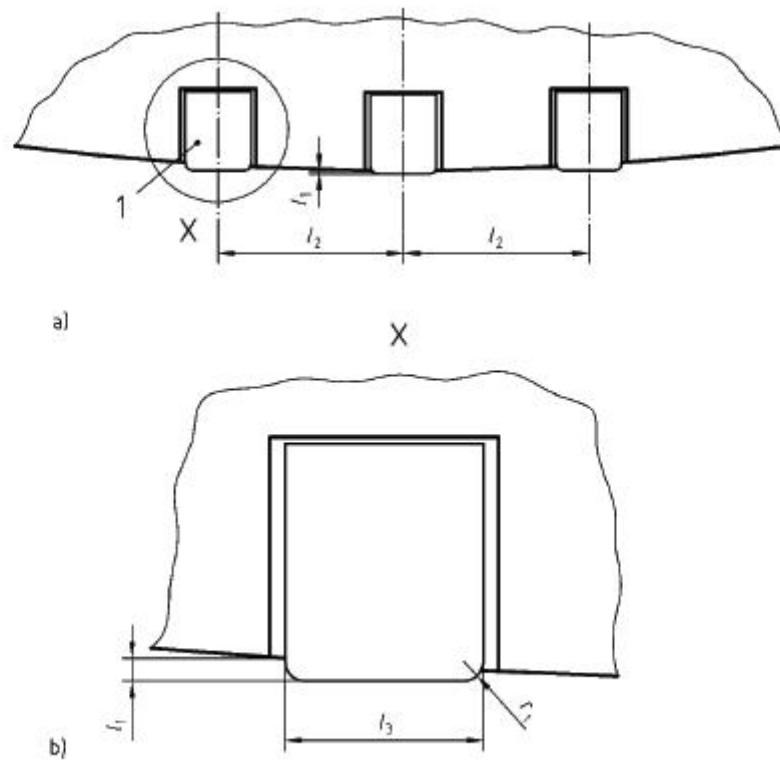

- a) The relative positions of the three force transducers  
 b) The relation of the exposed surfaces of the force transducers to the surface of the test knee

#### Key

- 1 Force transducer  
 $l_1$  Tolerance of the surface of each transducer compared to the contour of the "Kandy" knee,  $\pm 0,5$  mm  
 $l_2$  Distance between the centres of the force transducers,  $(28 \pm 2)$  mm  
 $l_3$  Diameter of the force transducers,  $(10 \pm 0,1)$  mm  
 $r_1$  Radius of curvature of the corners of the force transducers,  $(1,0 \pm 0,1)$  mm

Figure 3 — Dimensions of force transducers and their relationship to the test knee surface

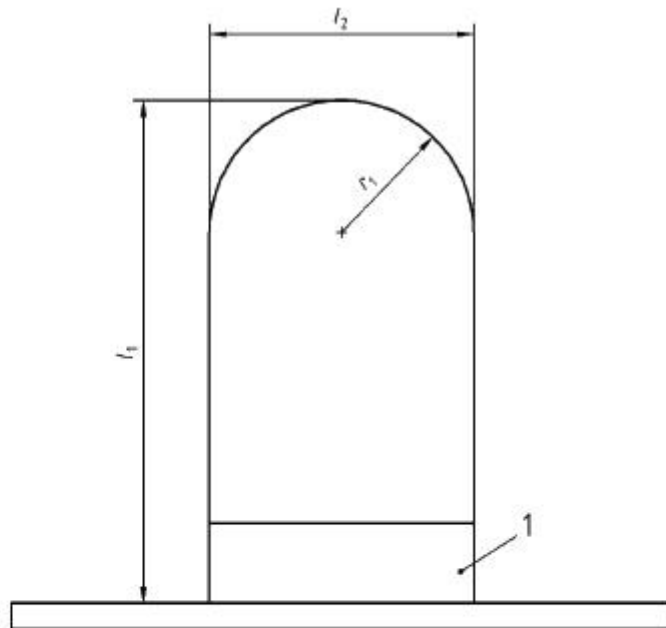
**Key**

- 1 Load cell or force transducer
- $l_1$  Height of the anvil,  $(220 \pm 20)$  mm
- $l_2$  Diameter of the anvil,  $(100 \pm 2)$  mm
- $r_1$  Radius of curvature of the anvil,  $(50 \pm 1)$  mm

**Figure 4 — Impact test anvil**

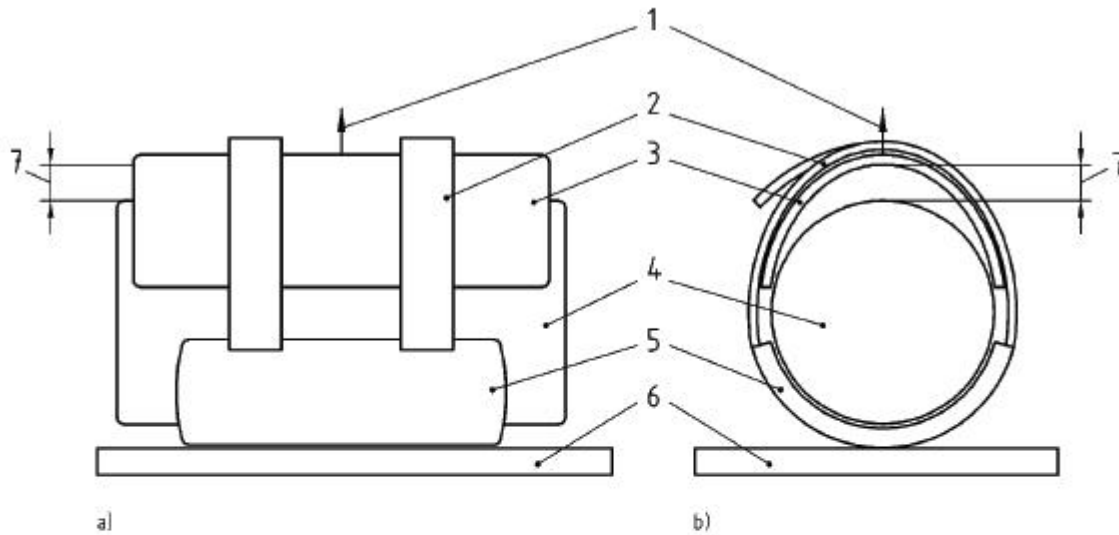

- a) side view  
b) schematic end view

**Key**

- 1 Direction of the applied force
- 2 Restraining straps of the knee protector
- 3 Light hollow metal or plastic half cylinder
- 4 Solid cylinder of wood, metal or plastic
- 5 Knee protector
- 6 Solid base
- 7 The distance the half cylinder moves on application of the force

**Figure 5 — Apparatus for assessing the compliance of restraint straps**

## EUT Photos

Photo 1 Appearance of EUT



Photo 2 Appearance of EUT



**Photo 3 Appearance of EUT**



**Photo 4 Appearance of EUT**



**Photo 5 Appearance of EUT**



**Photo 6 Appearance of EUT**



**END OF REPORT**